

MANUAL

Draw Wire Sensor

SERIES SX300

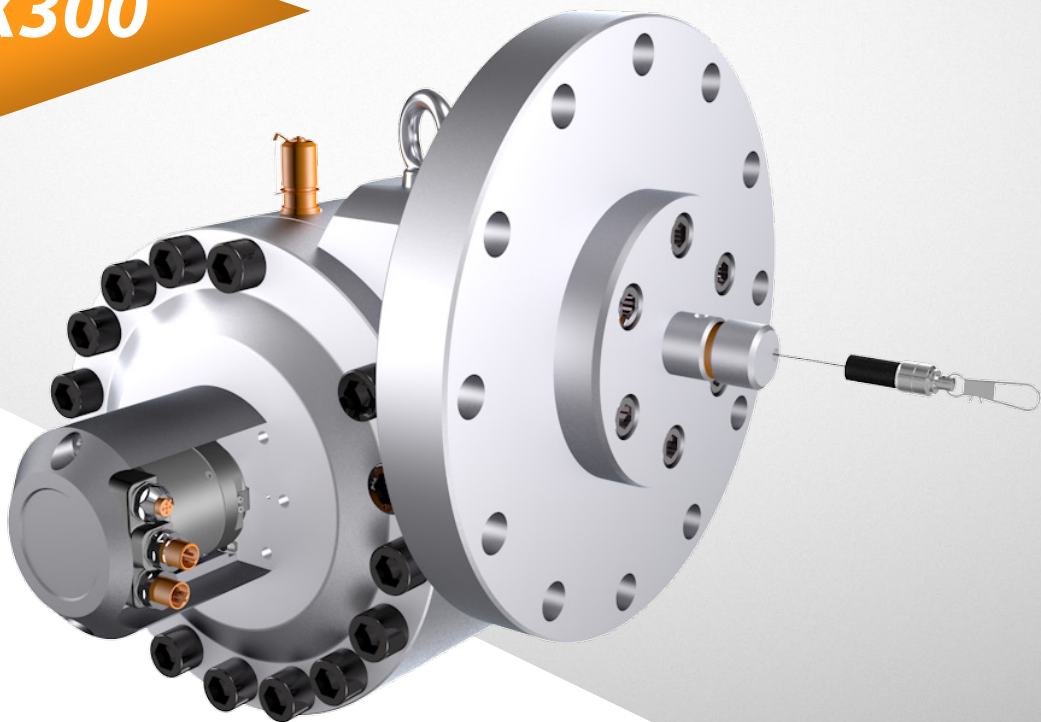

COPYRIGHT

This document is copyrighted by WayCon Positionsmesstechnik GmbH. Changes to, additions to and duplications of this manual are prohibited without the prior written approval of WayCon Positionsmesstechnik GmbH.

SUBJECT TO CHANGE

WayCon Positionsmesstechnik GmbH reserves the right to change this document without notice.

VERSION NUMBER

4.0

STAND

08.07.2020

CONTACT

WayCon Positionsmesstechnik GmbH
Mehlbeerenstraße 4
82024 Taufkirchen
Phone.: +49 89 679713 0
Fax: +49 89 679713 250
Email: sales@waycon.de
Internet: www.waycon.biz

TABLE OF CONTENT

1 GENERAL INFORMATION	4
1.1 Product identification	4
2 PRODUCT DESCRIPTION.....	4
3 TECHNICAL DATA	5
3.1 Technical Data Mechanic	5
3.2 Technical Data Encoder	5
4 Safety Instructions	10
4.1 Instructions for safe start-up	10
4.1.1 Flushing of transducer and cylinder.....	10
4.1.2 Venting of transducer	10
4.1.3 Initial testing of encoder	10
4.1.4 Initial testing of transducer	10
4.2 Instructions for safe use	10
4.2.1 Operating medium	11
4.2.2 Regular checks of screwed connections and leak tightness	11
4.2.3 Double acting cylinders.....	11
4.3 Instructions for safe handling	11
5 INSTALLATION.....	12
5.1 General Information Notes	12
5.1.1 Wiring and electrical connections.....	12
5.1.2 Fixing devices and screws	12
5.1.3 Mounting position and accessibility.....	12
5.1.4 Applying extra weight to the transducer	12
5.2 Fixation of the wire at the piston	13
5.3 Mounting procedure instruction	13
5.8 Mounting of a rotary transducer with shaft.....	15
5.9 Mounting of the Series M36	16
6 MAINTENANCE AND SERVICE	17
6.1 Maintenance Plan.....	17
6.2 Elimination of failures during operation.....	17
6.3 Encoder change	18
6.4 Disassembly of transducer	19
6.5 Changing o-ring seals of flange assembly	23
6.6 Final work after dismantling.....	24
6.6.1 Storage.....	24
6.6.2 Tightening torques for screws.....	24
7 Spare parts	24
7.1 Exploded view	24
7.2 Exploded view - encoder assembly and attachment parts.....	25
7.2.1 Part list - encoder assembly and attachment parts	25
7.3 Exploded view – flange assembly	25
7.3.1 Part list – flange assembly.....	26
7.4 Exploded view – transducer housing.....	26
7.4.1 Part list – transducer housing	26
8 EXAMPLE TEST REPORT	27

1 GENERAL INFORMATION

1.1 Product identification

All transducers are marked with a label and a security note. Additionally the serial number is stamped into the transducer housing nearby the test point. For any questions regarding the transducer or spare parts, please specify the type and serial number.



CAUTION:
DO NOT LET CABLE
SNAP BACK
THIS COULD DAMAGE THE SENSOR

2 PRODUCT DESCRIPTION

The WayCon SX300 Draw Wire Series is designed for use in combination with hydraulic cylinders and measuring the cylinder position. Especially designed for long stroke cylinders with pressurized housings to be flanged directly to the cylinder head. By giving feed back signals to a machine control unit, it is possible to control the position of a cylinder, to program specific movements or to manage synchronous movements of several cylinders. Due to its small overall size, its short assembly time and its possible customisation, this sensor technology is a cost-effective and flexible solution for a wide range of industrial applications.

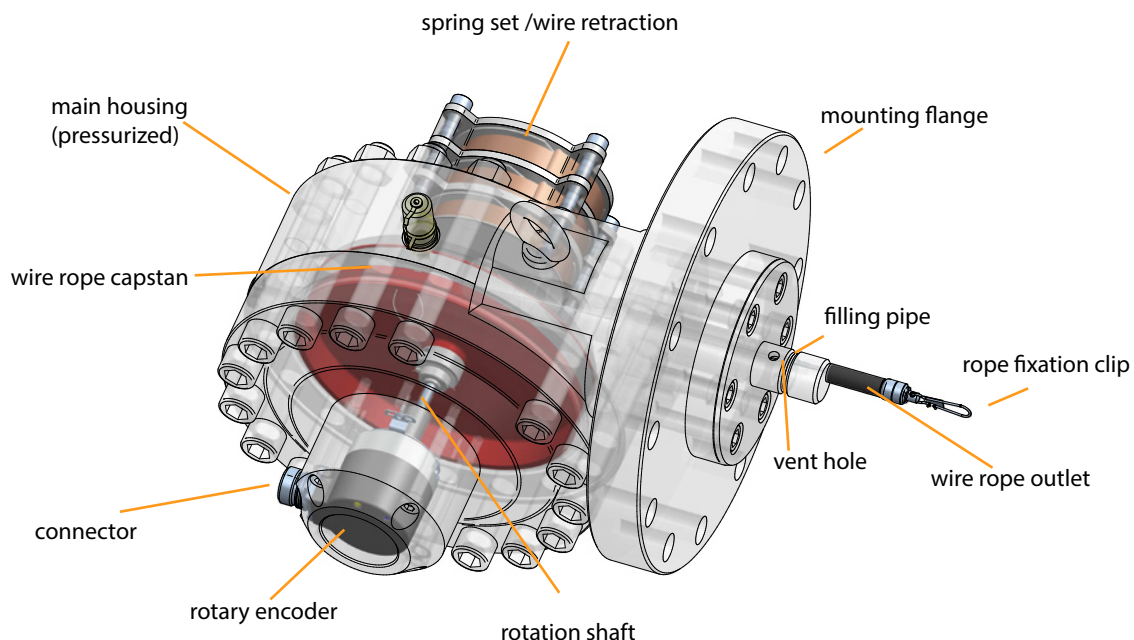

Typical Applications

- ▶ hydraulic gates for dam control
- ▶ synchronous run of more than one cylinder
- ▶ sluice gate control
- ▶ cylinder acceleration and speed control
- ▶ stroke control of fairground ride applications

3 TECHNICAL DATA

3.1 Technical Data Mechanic

Measurement range	[m]	10 / 15
Linearity	[%]	±0.05 (depending on the used encoder)
Sheave circumference	[mm]	568.9
Operating temperature	[°C]	-20...+70
Hydraulic fluid		only non-hazardous fluids (non-flammable, non-toxic), no gaseous media
Operating pressure	[bar]	300 (30 MPa)
Testing pressure	[bar]	400 (40 MPa)
Pressure port		Minimes 1620
Piston travel speed	[m/s]	max. 2 (in air) ¹⁾
Rope tension	[N]	start of measurement range: 10...11.5 (13...16.5) end of measurement range: 29...31.5 (37...43)
Wire sag (calculated)	[mm]	<30
Connector orientation		adjustable in 90° steps
Weight	[kg]	61
Housing ²⁾		42CRMo4 (1.7228)
Draw wire		stainless steel 1.4301, Ø 0.69 mm
Encoder requirements	[mm]	flange with stator coupling Ø 58 pitch circle diameter for fixing screws 63 hollow shaft Ø 15

¹⁾ identified laboratory value without hydraulic fluid

²⁾ In case of outdoor use we recommend to varnish the housing additionally. Attention: Do not varnish moving parts (encoder shaft, coupling...!)

3.2 Technical Data Encoder

Output signal Link to the encoder		SSI 8.5883. 6624.G322	CANopen 8.5888. 6622.2123	Profibus-DP 8.5888. 6632.3113	EtherCAT 8.5888. 66B2.B212	Profinet 8.5888. 66C2.C212	4...20 mA M36-SC-K-10- 420A-SR12-IP67	
Linearity	[%]	±0.05 (independent of the measurement range)						
Resolution scalable (via Software)		no	yes				no	
Resolution standard	[Pulses/mm] [Bit]	14,4 13	14.4 13				- 12	
Sensor element		Multiturn-Absolute-Encoder with optical disc						Multiturn- magnetic
Connection		connector M23, radial, 12 pins	2 x connector M12, radial	3 x connector M12, radial	3 x connector M12, radial, 4 pins		connector M12, radial, 5 pins	
Power supply	[VDC]	10...30, reverse polarity protection of the power supply						
Current consumption (no load, 24 VDC)	[mA]	max. 50	max. 100	max. 120		max. 200	max. 30	
Protection class		IP67						IP67
Humidity		max. 90 % relative, no condensation						-
Temperature	[°C]	-40...+90	-40...+80			-40...+85	-40...+85	
Special cables needed		yes						no
Link to manual		-	CANopen	Profibus-DP	EtherCAT	Profinet	4...20 mA	
Link to device file		-	EDS	GSD	XML	GSDML	-	

3 TECHNICAL DATA

3.2 Dimensions

Flange type F1 (rod sealing) for SSI / PROF / CAT / CAN / NET

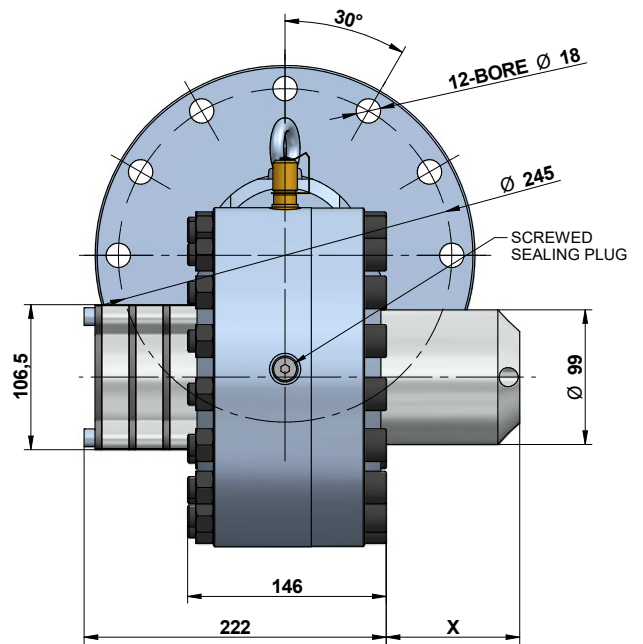
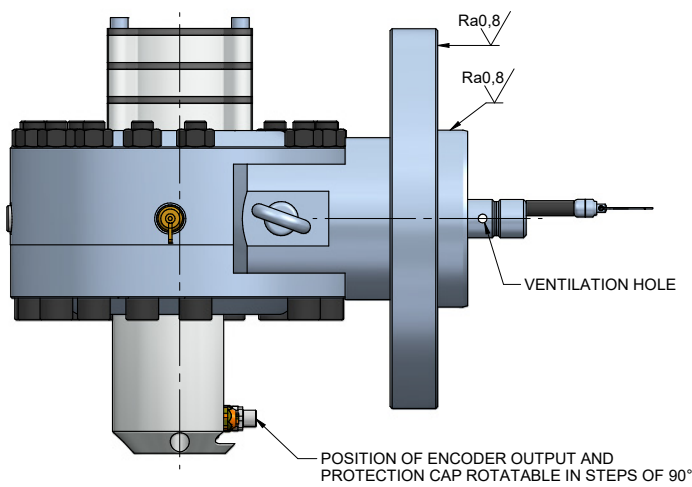
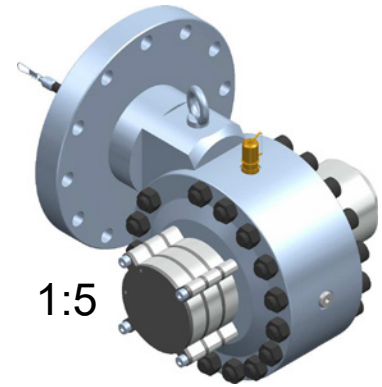
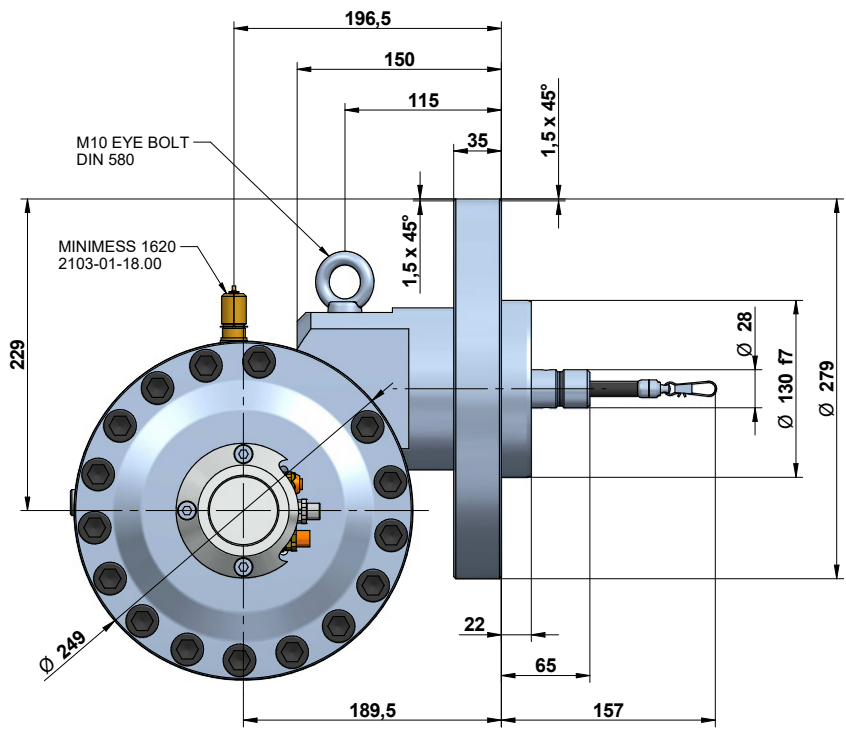

encoder cap:
 for SSI encoder: X = 71 mm
 for Profibus encoder: X = 98 mm
 for EtherCAT encoder: X = 98 mm
 for CANopen encoder: X = 98 mm

3 TECHNICAL DATA

Flange type F2 (piston sealing) for SSI / PROF / CAT/ CAN / NET

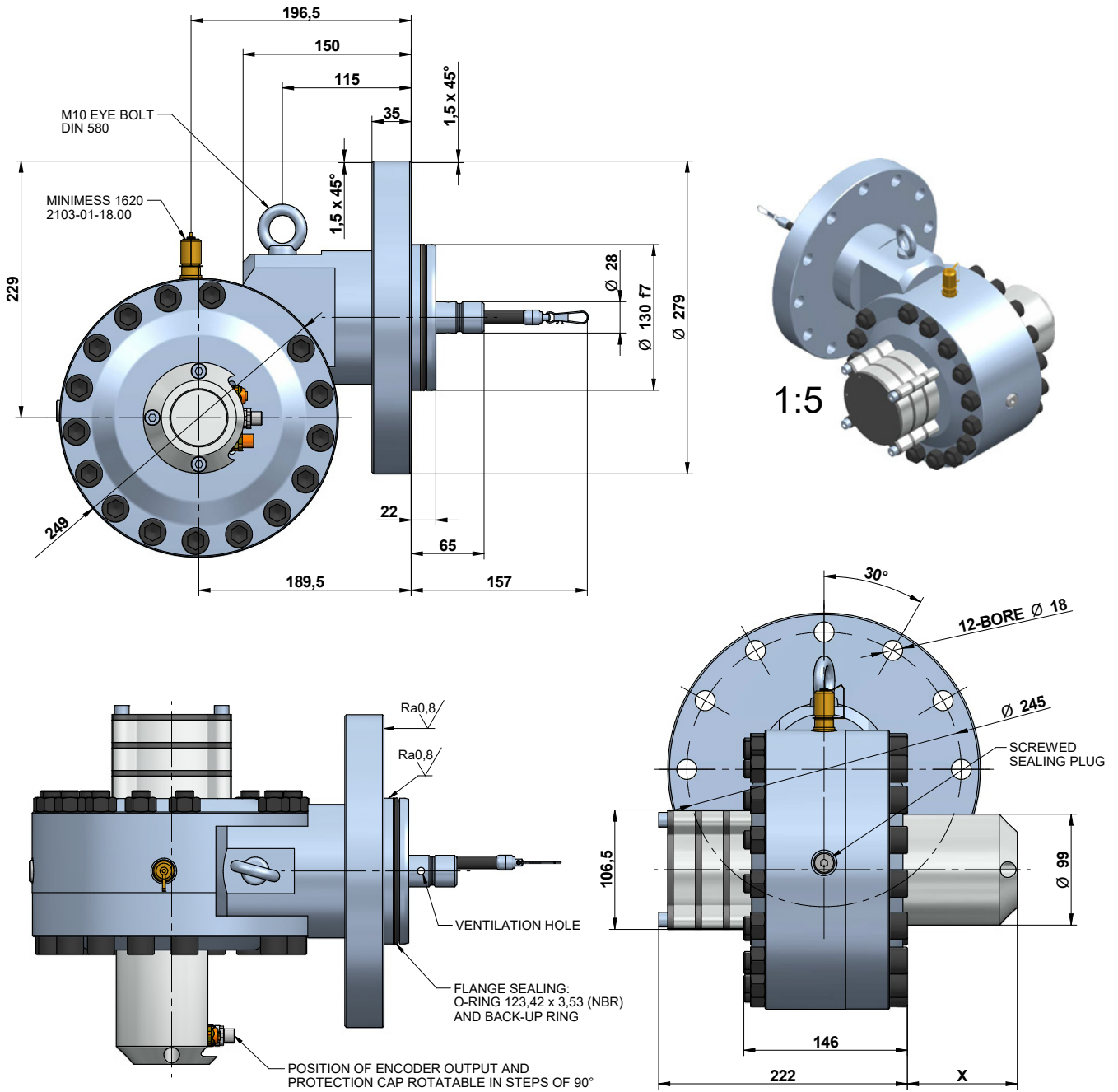

encoder cap:	
for SSI encoder:	X = 71 mm
for Profibus encoder:	X = 98 mm
for EtherCAT encoder:	X = 98 mm
for CANopen encoder:	X = 98 mm

3 TECHNICAL DATA

Flange type F12 (rod sealing) for 4...20 mA

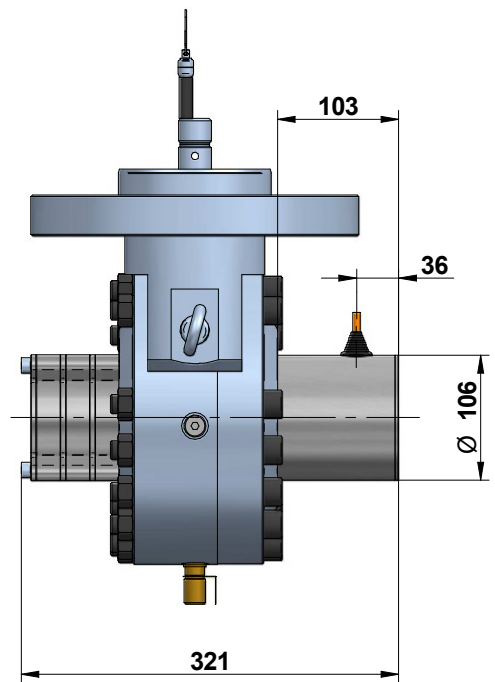
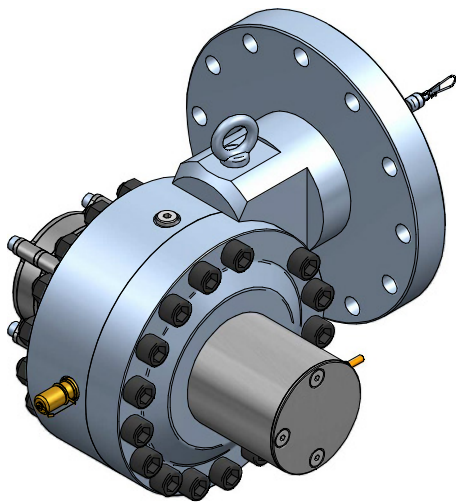
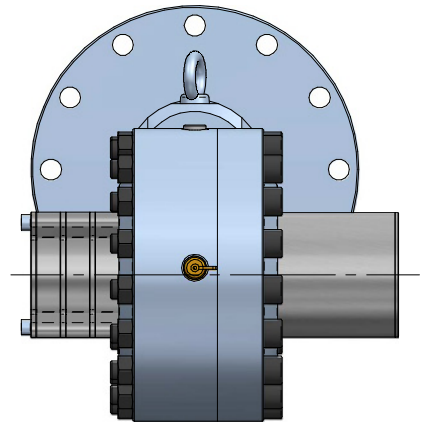
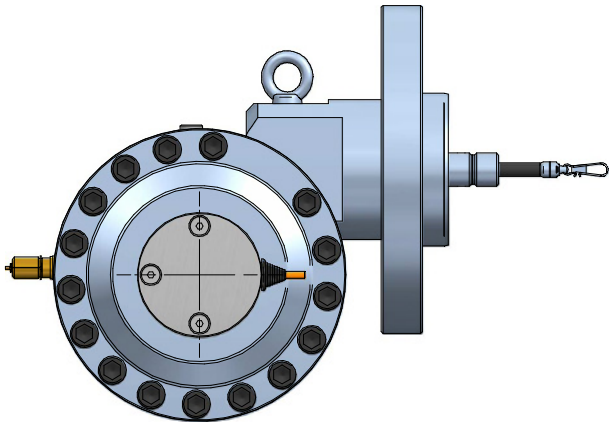

Variants with water drain possible

3 TECHNICAL DATA

Flange type F22 (piston sealing) for 4...20 mA

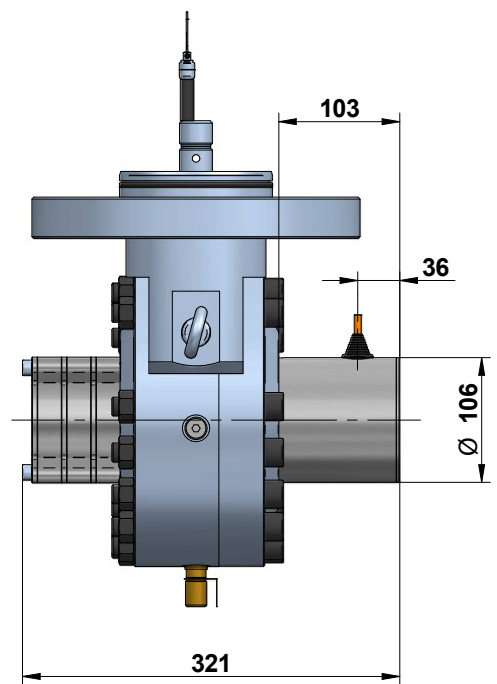
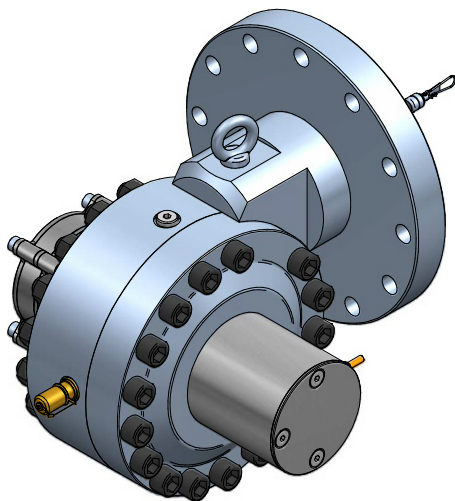
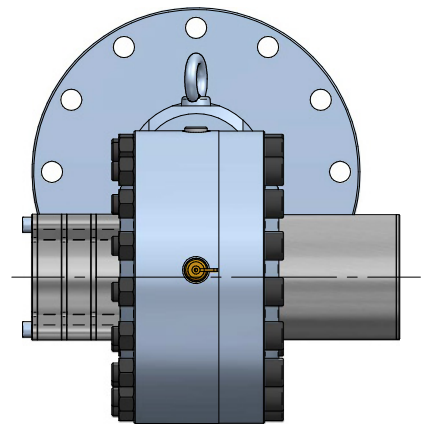
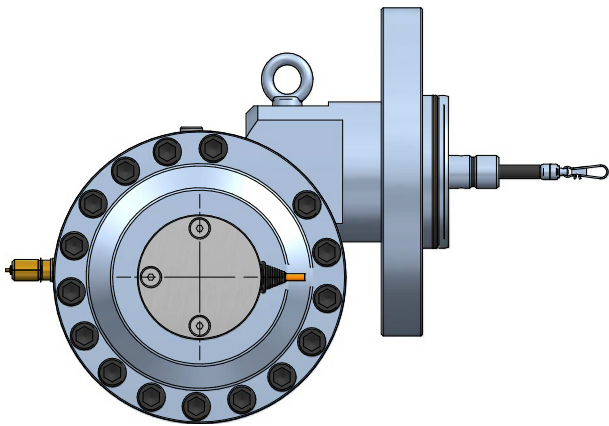

Variants with water drain possible

Option: K1 / K2 / K3

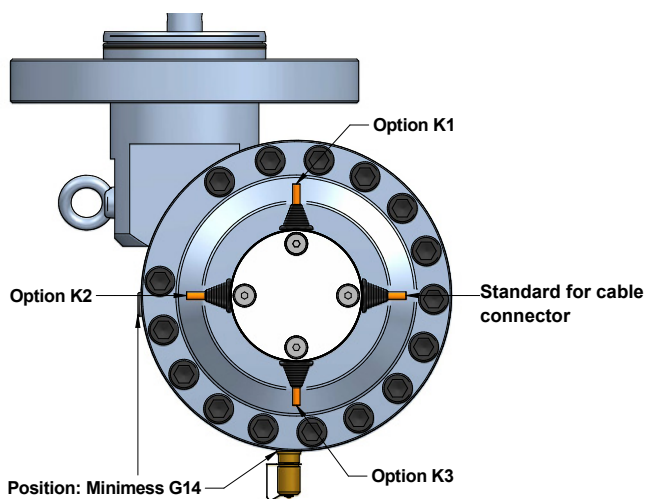

4 SAFETY INSTRUCTIONS

4.1 Instructions for safe start-up

Start-up is permitted only, if it is ensured that

1. all fixings and connections have been installed correctly.
2. the plant / the components have been filled with the proper oil.
3. the laid piping and the hydraulic cylinder have been cleaned inside and were duly flushed prior to combining the system.

4.1.1 Flushing of transducer and cylinder

Before the application may be initially operated at full operating pressure and operating speed, all components must be flushed thoroughly. Please refer to the cylinder instruction guidelines.

4.1.2 Venting of transducer

Before operation it is necessary to vent the transducer via the test point connection or the screwed sealing plug. Please make sure that in both cases the used vent hole is the highest point of the transducer. Proper venting is indicated so that the oil is free from bubbles and foaming. (Minimes and plug are interchangeable.)

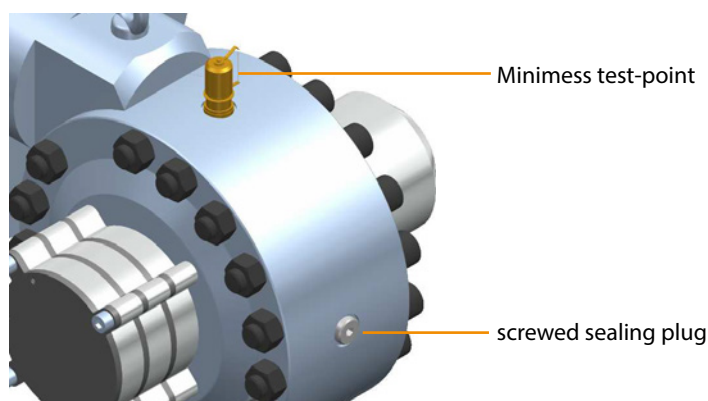

4.1.3 Initial testing of encoder

Connect the encoder in a de-energized state only. Make sure that the operating voltage for the encoder is correct and the max. permissible output current is not exceeded (see technical data). The operating voltage for encoder and succeeding device must be turned on and off together. For setting up functions refer to the technical data chapter.

4.1.4 Initial testing of transducer

As soon as the operating temperature has reached the specific value, the plant must be shut down. After this all screw connections must be checked and tightened, if necessary.



Note: Avoid that eyes and skin get in contact with the operating medium. (Consult a physician, if required).

4.2 Instructions for safe use

The transducer may be used only fixedly installed to a hydraulic cylinder in suitably safeguarded applications. Keep your plant as clean as possible. This ensures you a trouble-free operation and a long service-life. Please follow the instructions of all applicable manuals:

- ▶ this instruction manual
- ▶ hydraulic cylinder guidelines/manual
- ▶ encoder manual

4 SAFETY INSTRUCTIONS

4.2.1 Operating medium

During operation the maximum oil temperature must not exceed +70 °C! Continuous monitoring is indispensable. If necessary, a cooling system must be provided. The operating medium must be checked for contamination or ageing in regular intervals, so that it can be exchanged in time. Refilling only with compatible oil. Please refer to the hydraulic cylinder guidelines. The use of the sensor is only permitted with non-hazardous hydraulic fluids (not-flammable, non-toxic).

4.2.2 Regular checks of screwed connections and leak tightness

Tightening of screwed connections is part of the regular maintenance. A constant maintenance must be independently and sufficiently ensured by the user of the application. The main housing of the transducer, the rotating shaft sealing and the flange connection between transducer and cylinder have to be checked regularly on leak tightness.

4.2.3 Double acting cylinders

Do not use the SX300 in combination with a double acting cylinder.



Note: The responsibility of performing a regular maintenance service rests with the operator of the facility. WayCon will not carry out any maintenance service, neither in the course of new installation nor in the course of warranty or guarantee services!

4.3 Instructions for safe handling

According to the weight of the transducer a suitable lifting device (crane) must be used for installation. Care must be taken that the applied belts are designed in such a way that loosening during handling as well as any possible damage of the transducers is impossible. It is not allowed, to lift the hydraulic cylinder at the eye bolt of the transducer. Be aware of the Minimesstest-point near by the eye bolt.

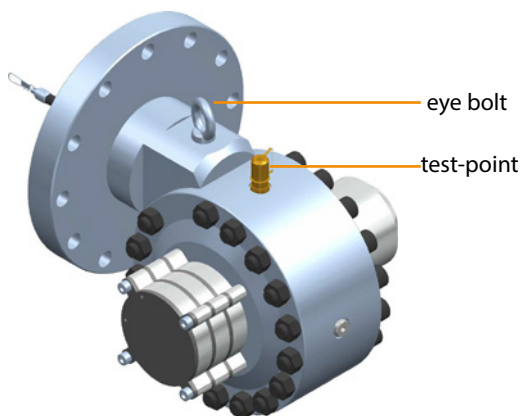

Note: It is not allowed to lift the hydraulic cylinder at the transducer lifting device (eye bolt). It is also not allowed to use the eye bolt of the transducer to do any positioning of the hydraulic cylinder at. Please refer to the hydraulic cylinder guidelines.

5 INSTALLATION

5.1 General Information Notes

The installation of the transducer to the hydraulic cylinder must be done by trained and qualified fitters only.

5.1.1 Wiring and electrical connections

To avoid damage due to wrong wiring we strongly recommend to do the electrical connection according to the wiring instructions of the encoder.

All existing safety devices for electrical installations have to be ready for operation and must be checked regularly.

- ▶ Before setting in operation, connect all required strands as per data sheet. To prevent short-circuits, neatly insulate the ends of all strands which are not required.
- ▶ When pre-assembling the mating connector, comply with any instructions accompanying the connector.
- ▶ Our recommendations regarding cable lengths:
 - in case of asymmetrical transmission, i.e. inverted signals are not used, cable length max. 10 m.
 - in case of symmetrical transmission (e.g. to RS 422), cable length max. 50 m (cable with twisted pairs of wires).
- ▶ Plug in or pull out mating connector at the encoder only when encoder is de-energized.
- ▶ Make certain that the operating voltage is correct and the max. permissible output current is not exceeded (see data sheet).
- ▶ The operating voltage for encoder and succeeding device must be turned on and off together.

In order to maintain CE-Conformity the EMC installation conformity must be followed. Shielded cables should be used for control lines. The cable shield should, if possible be connected fully enclosed (360°) by shielded connectors or cable bushings. This has to be done at the encoder and transmission end.

- ▶ The protection earth should be put with low impedance on both face and back of the encoder and the transmission end.
- ▶ In case of earth loop problems, the protection earth of the encoder side has to be removed. On this occasion the encoder should be placed electrically isolated opposite the actuation.
- ▶ The encoder lines should run separately from cables with high noise levels. Consumers with high disturbance levels, e.g. frequency converters, solenoid valves, contactors etc. should not be connected to the same voltage supply. Otherwise, a suitable voltage filtering has to be installed.



Note: Please refer to the additional encoder instruction guidelines.

5.1.2 Fixing devices and screws

The bolts, nuts and stud bolts used for fixing the transducer to the cylinder must be at least of quality 8.8. Please refer to the cylinder manual.

5.1.3 Mounting position and accessibility

Generally the transducer can be installed in any mounting position desired. However the mounting position shall be chosen in such a way that a good accessibility with respect to later maintenance is ensured. For proper ventilation the testpoint or screwed sealing plug must be the highest point of the sensor.

5.1.4 Applying extra weight to the transducer

The transducer must always be installed in such a way to the cylinder that no extra load is applied to the transducer. This means that no other parts or holders are allowed to be fixed to the transducer. If an additional housing is required, it must be fixed directly to the hydraulic cylinder, not to the transducer.



Note: The transducer must always be installed to the cylinder in such a way that no extra load is applied to the transducer. This means that no other parts or holders are allowed to be fixed to the transducer. Do not move or lift the cylinder by exercising force to the transducer.

5 INSTALLATION

5.2 Fixation of the wire at the piston

Use a suitable fixation for the wire inside the cylinder. WayCon recommends to install a "clipfixation" unit, that is screwed into the piston. It is available as accessory.

Piston wire fixation

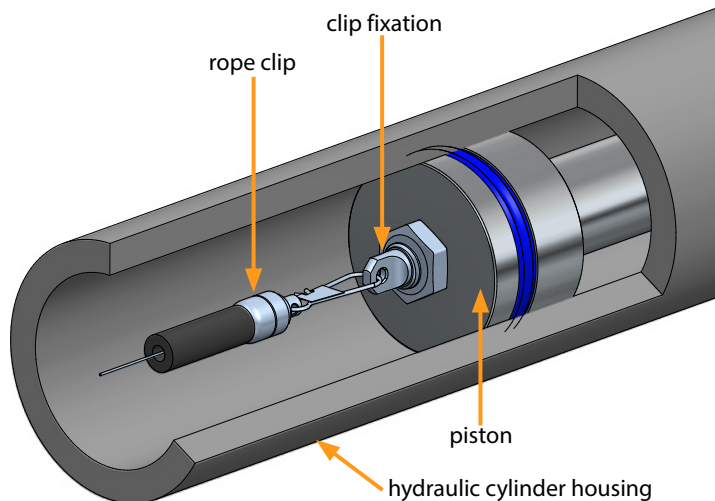

Clipfixation M8

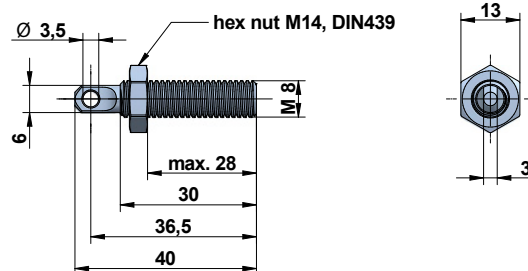

Clipfixation M14

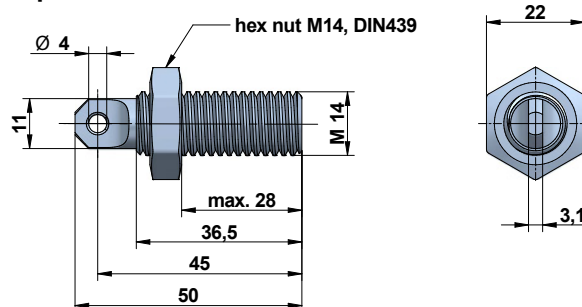

Note: Because the rope must be extracted vertically from the sensor (maximum variation from the vertical is 3°), it is very important to choose the wire fixation point at the piston in its center. If the wire gets extracted at an inclination the durability of the wire is reduced considerably and a wire breakage will be unavoidable in the end.

5.3 Mounting procedure instruction

Please make sure that the SX300 has the correct measurement range, before starting the installation.

In order to calculate the correct measurement range the pre-extraction (distance between the piston and the sensor, while the piston is in its end position = the closest to the SX300; picture 1) has to be deducted from the nominal measurement range. The result is the actual usable measurement range.

As a result the nominal measurement range of the SX300 has to be greater than the cylinder stroke + the pre-extraction + reserve (picture 2).

If the calculation of the measurement range was done incorrectly, a tearing of the wire rope may happen!

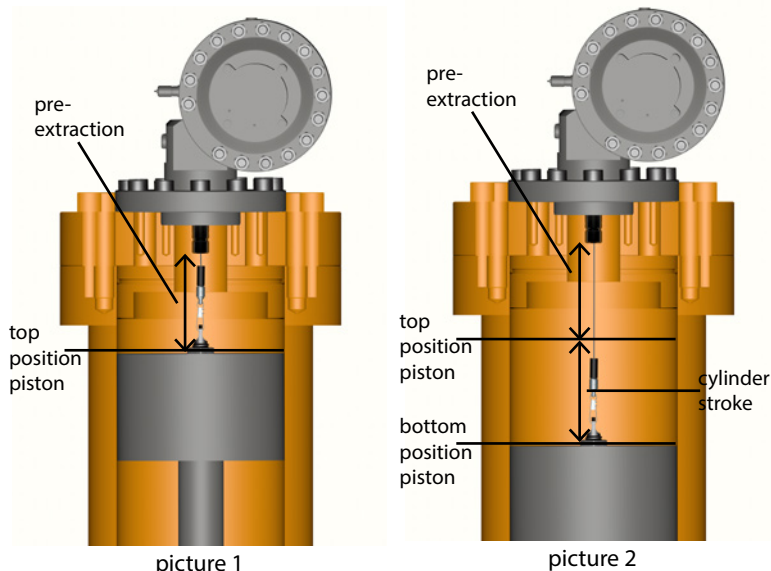

5 INSTALLATION

The wire fixation unit has to be screwed into the piston of the cylinder and locked with counter nut.

Note:

Use screw locking device. If it is not possible to work through the cylinder head bore, you have to take off the cylinder head (please refer to the cylinder manual).

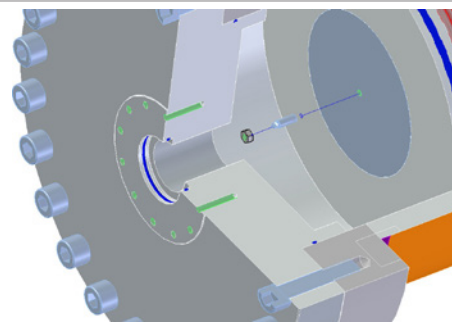

Install 3 stud bolts at the cylinder head.

It is necessary to use stud bolts on the underside of the Sensor flange, as conventional screws (e.g. according to DIN 912) cannot be mounted for space reasons.

Note:

Studs have to be greased with MoS2 during assembly, unless otherwise described. Please follow the operating instructions for the cylinder.

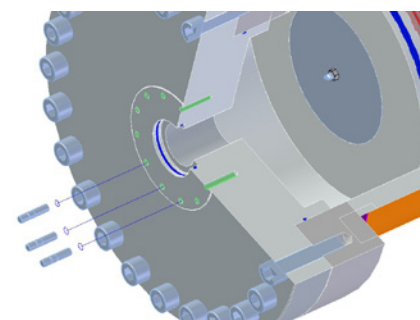

Move the transducer near the cylinder bore. Use a crane if necessary. Remove the red protective cap at the cable outlet of the sensor. Open the rope clip, guide the rope through the hole and hang the rope clip in the clip fixation. Finally, close the rope clip again.

Note: Do not let the draw wire snap! If the draw wire retracts freely into the sensor, it can cause injury and damage the device. Take care when unhooking and retracting the draw wire into the sensor. Avoid leading the draw wire over edges or corners.

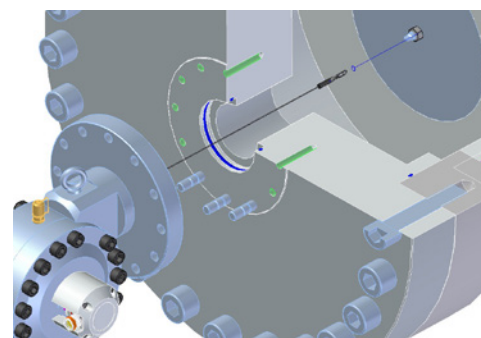

Move the transducer toward the cylinder head and insert the stud bolts through the bores in the flange.

Note:

Avoid leading the rope over edges or corners. Be careful not to damage the O-ring. Do not operate the sensor if there are buckles or damages in the draw wire. Tearing the draw wire may cause injury or damage to the sensor.

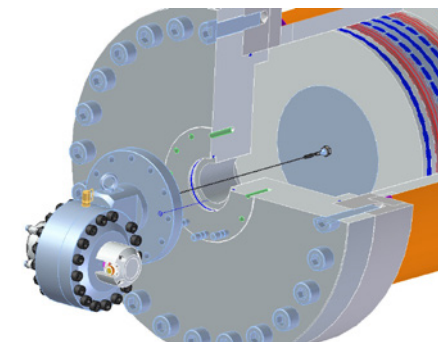

Mount the fixing screws through the flange and tighten them crosswise with a torque of 100 Nm in the first step.

Note:

The fastening screws must be greased with MoS2 during assembly, unless otherwise described. Please follow the operating instructions for the cylinder.

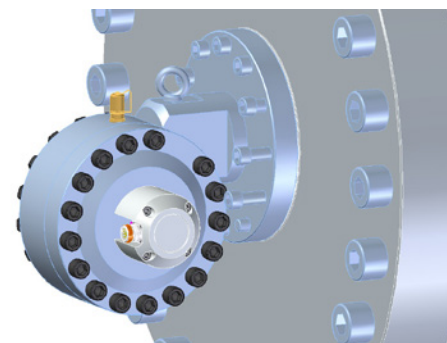

5 INSTALLATION

Screw the nuts onto the stud bolts at the bottom of the flange. Tighten the bolts and nuts crosswise to the specified torque. Observe the following values if the manual of the cylinder does not prescribe a torque:

- 145 Nm for M16, quality 8.8
- 215 Nm for M16, quality 10.9
- 250 Nm for M16, quality 12.9

Note:

The nuts must be greased with MoS2 during assembly, unless otherwise specified. Please follow the operating instructions for the cylinder.

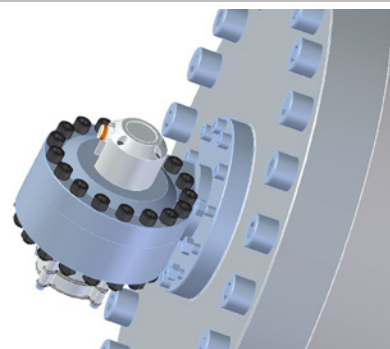

5.8 Mounting of a rotary transducer with shaft

Note:

It is mandatory that the rotary transducer has a clamping flange of 36 mm, shaft \varnothing 10 mm and shaft length of 20 mm

Step 1:

Mount the coupling onto the shaft of the rotary transducer. Make sure to leave a gap of 4 up to 5 mm between coupling and rotary transducer flange.



Step 2:

Mount the rotary transducer onto the adapter flange with three DIN912 M4x20 screws. Use the bores as shown.

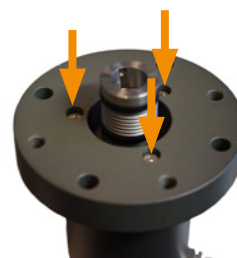

Step 3:

Mount the adapter flange with the rotary transducer onto the SX300. To fix, use four DIN912 M8x55 screws and four spacer sleeves 8x14x35.

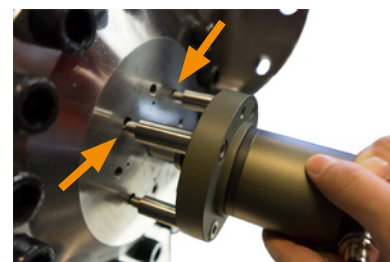

Step 4:

Secure the coupling to the SX300 shaft by tightening the two setscrews. Use a torque of 2 up to 2.5 Nm.

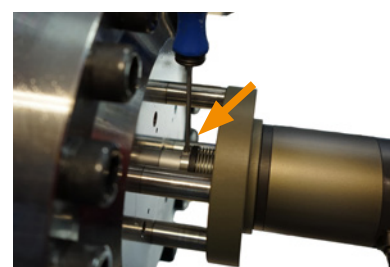

Attention: Do not apply excessive force!

Step 5:

Fix the protection cap with three M8x90 (for Series Encoder M36) screws. Make sure that the opening leaves the connector output free.

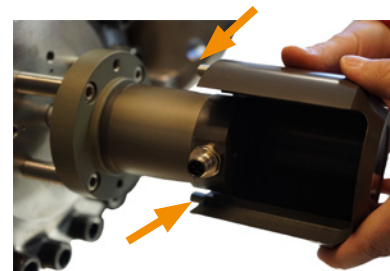

5 INSTALLATION

Protection cap completely mounted.

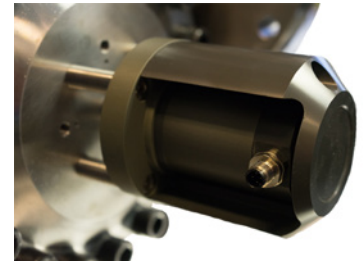

Draw wire sensor SX300 with the completely mounted rotary transducer



5.9 Mounting of the Series M36

Example: SX300-15-M36-420AT-F22, cylinder stroke 9.5 m

Nominal measurement range SX300: 15 m

Output signal: 4...20 mA

The output signal is approx. 4 mA while the wire rope is retracted.
The output signal is approx. 20 mA while the wire rope is extracted.
The wire rope gets connected to the piston, while the piston is in its top position (picture 1). In case this pre-extraction would be 1 m, the output signal would be 5.07 mA. As the cylinder stroke is 9.5 m, the output signal at the pistons bottom position would be 15.2 mA.

In this example the wire rope would be totally extracted for 10.5 m.
For this reason a SX300 with a nominal measurement range of 10 m would not be sufficient, although the cylinder stroke is only 9.5 m.

Note:

Please use for teaching of the rotary transducer the manual of the Series M36 ([Link](#))

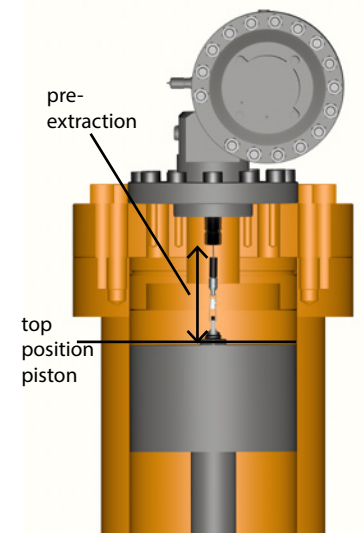

picture 1

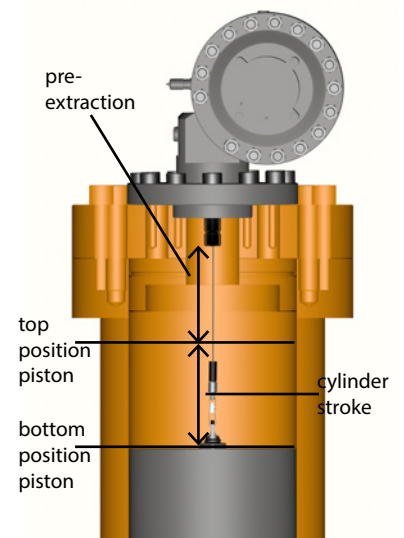

picture 2

6 MAINTENANCE AND SERVICE

Proper maintenance includes the regular check of the operating medium, check for leakages, check of encoder fixation and the output signal control.

6.1 Maintenance Plan

This maintenance plan gives you a general outline about the recommended intervals of servicing the SX300. The need for replacing certain components strongly depends on the application and the environmental conditions that the SX300 is used in. For example a SX300 that performs 50 full strokes per day and is exposed to wind and weather, should obviously be serviced more often, than a sensor that is installed indoors and used only once or twice a day.

Action	Description	Interval every	Responsible
Checking for oil leaks	Detailed examination of the housing for signs of leaking hydraulic oil. (Special attention on Minimes and sealing plug)	6 months	Service technician
Checking for damage in the protection coating	Detailed examination of the housing for signs of chipped areas, or rust	6 months	Service technician
Recommended replacement of the spring package	full stroke per day : 1/10/25 more than 50 full strokes per day	10/6/5 years 3 years	specially trained and WayCon certified personnel
Checking of encoder	Detailed examination of the encoder for signs of wear, rust, moisture ingress etc.	6 months	Service technician
Checking of electrical connection	Detailed examination of the cable for signs of damage of the insulation, cable gland etc.	6 months	Service technician
Replacement of the measurement cable	necessary only in case of a cable break		WayCon technician

6.2 Elimination of failures during operation

In spite of correct installation, normal use and regular maintenance, there may be failures in mechanical or electrical matters. Please refer to following table:

Fault	Cause of trouble	Repair
Leakage	Leakage above flange connection	Exchange o-ring between transducer flange and cylinder head, check seal face at cylinder/transducer
	Leakage above transducer housing	Dismantle, exchange o-ring of transducer housing, exchange of all sealings is recommended!
	Leakage above rotating shaft either on spring side or encoder side	Dismantle, check rotating shaft for damage, new rotating shaft, new seal, new bearing, exchange of all sealings is recommended!
	Leakage of flange, flange adapter and flange	Dismantle flange and filling pipe, check o-rings and back-up rings of filling pipe, check o-rings of M12 screws, exchange of all sealings is recommended!
No encoder output signal in general	No supply	Check connector and wiring.
	Wrong or broken connection	Check connection, check encoder, change encoder
	Supply over-voltage	Check supply, check encoder, change encoder
Piston moves without change of signal and without transducer shaft rotation	Broken wire inside cylinder	Dismount transducer from cylinder, dismantle transducer, check springs, new spring set, new wire set, new rotating shaft and seal
Piston moves without change of signal and without encoder rotation	Encoder hollow shaft loose	Tighten the hollow shaft onto the rotation shaft of the transducer
High hysteresis in output signal	Encoder stator coupling broken or loose	Check encoder stator coupling, change if necessary



Note: We highly recommend to carry out all repairs by transducer specific skilled and trained fitters only.

6 MAINTENANCE AND SERVICE

6.3 Encoder change

Unplug the encoder and remove the protection cap.

Note:

- ▶ Hollow shaft encoder. Do not apply radial force to the encoder. The rotating shaft and stator coupling could get damaged.
- ▶ The protection cap may vary depending on the encoder design.

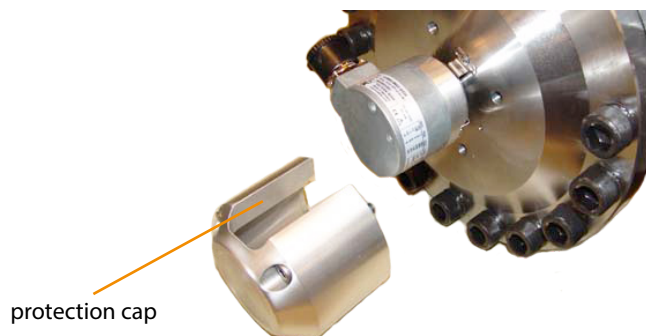

Loosen the clamp screw of the hollow shaft.



Remove the 2 encoder fixation screws. Pull the encoder carefully off in axial direction.

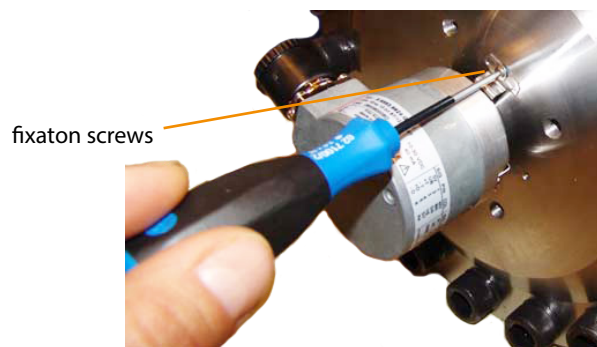

Installation in reverse order.

- ▶ Loosen hollow shaft screw before installing the encoder onto the shaft.
- ▶ Use screw locking device (e.g. Loctite 243) for the encoder fixation screws
- ▶ The connector orientation can be chosen in 90 degree steps.

Note:

Please refer to the encoder guidelines supplied by the encoder manufacturer and delivered with the encoder/transducer.

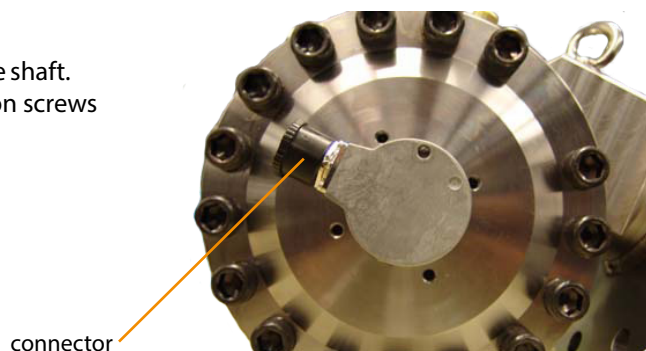

Important Note:

The procedures that are described in following chapters (including disassembly and assembly of the transducer) may only be carried out by specially trained persons. Special knowledge about draw wire transducer technology is necessary which can not be generally assumed by hydraulic fitters.

Non-observance can have severe consequences and lead to

- ▶ injury
- ▶ expensive standstills of operation
- ▶ loss of occupational safety
- ▶ loss of warranty

6 MAINTENANCE AND SERVICE

6.4 Disassembly of transducer

Before dismantling, remove transducer from the cylinder (see chapter installation).

Loosen 16 pcs. main housing screws and take 14 pcs. completely out. Leave 2 pcs. opposite wise lightly tightened.

Loosen 4 pcs. spring housing screws with holding the spring housing against the spring torque. Turn back the spring set and pull out the wire rope of the transducer at the same time.

Note:

Only by transducer specific trained persons. The stored energy of the spring may lead to injuries when being mishandled.

As soon as the wire rope is completely pulled out, the springs can be turned back to zero torque. Remove spring set with holding back the center spring hook to avoid a uncontrollable spring roll off.

Note:

Only by transducer specific trained persons. The stored energy of the spring may lead to injuries when being mishandled. Sufficient energy is stored into the spring even if the spring set is turned to zero torque.

Remove encoder (see chapter 6.2). Loosen 2 screws of the encoder adapter and remove it in axial direction.

Note:

Do not bend or apply radial force to the rotation shaft and encoder adapter. The rotation shaft and seal could be damaged.

Remove the last 2 screws from the main housing. Remove the main housing cap in axial direction without tilt. Remove the o-ring.

Note:

The main housing cap must not be cant. Be aware of the rotation shaft and do not apply radial force to the shaft. The rotation shaft and seal could be damaged.

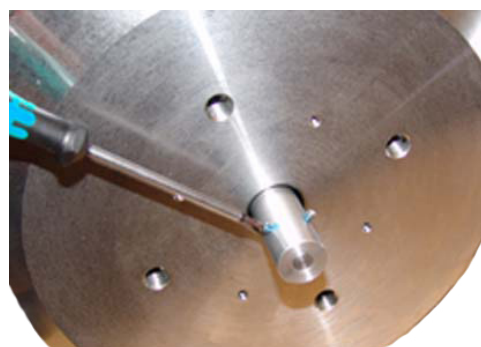
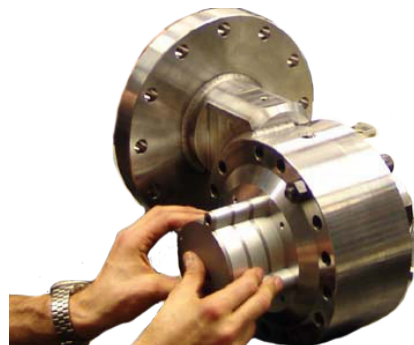
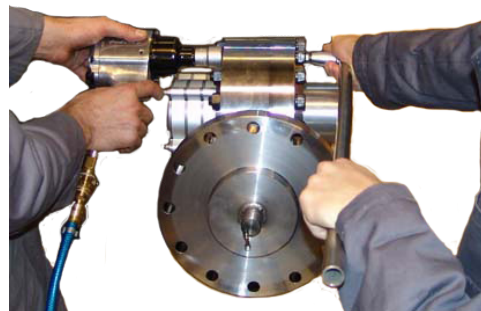

6 MAINTENANCE AND SERVICE

Cut the wire close to the transducer and turn the rotating shaft until the wire is completely inside the sensor housing. Loosen the wire capstan clamp.

Note:

Do not try taking out the wire capstan before cutting the wire. Narrow wire rope gap!



The wire capstan is now released and can be taken out of the main housing.

Pull out the capstan and remove the 3x18 cylinder bolt as well as the shim ring (e. g. 6x12x0,2).

Note:

Any assembly only with new wire rope set.



Pull out the rotation shaft to the spring housing side.

Note:

Only by transducer specific trained persons. Do not bend or apply radial force to the rotation shaft. The rotation shaft and seal could be damaged.

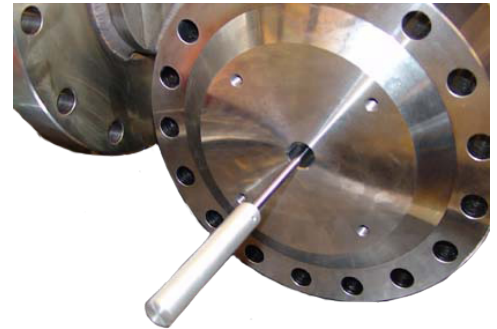

Before assembling the transducer change rotating shaft seals (2 pcs.) and bearings (2 pcs.) installed in the main housing and main housing cap. Check rotation shaft against axial run out, wear and abrasion. Check surface against notches and scratches. Change rotation shaft if necessary.

Note:

A worn out rotation shaft could damage new pressure seals immediately.



Feed the new wire rope through the wire outlet of the main housing.

Note:

Only use a pre-assembled new wire rope set. Check transducer housing parts, seal face and o-ring groove against damage and dirt.



6 MAINTENANCE AND SERVICE

Install the rotation shaft and push it until it is standing 5 up to 10 mm above the bearing. Install the washer onto the shaft. Mount the cylinder bolt 3x18 centered in the shaft.

Note:

If the shaft is pushed completely into the main housing, the wire capstan can not be installed due the narrow wire rope gap.



Install clamp ring and feed the wire rope through the fixation bore of the capstan. Crimp the wire as a loop for fixation (special tools are necessary).

Note:

Faulty workmanship can lead to a wire rope loosening during operation.



Place the capstan onto the shaft and guide the wire through the groove in the wall. Push the capstan into the housing as far as the cylinder bolt will fit into the slot of the capstan. Finally pull the wire straight.

Note:

Be aware of the narrow gap between housing and capstan. Do not jam wire rope between main housing and capstan.

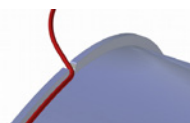
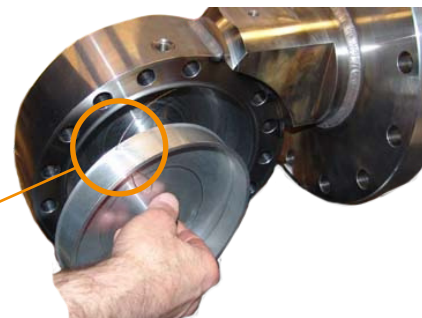

Push the rotation shaft until it reaches the end stop. Fix the clamp ring of the wire capstan (use screw locking device). Clean the shaft from screw locking device.

Note:

Prevent any contact of the screw locking device with seals and bearings. This could cause damage.



Install a new o-ring to the main housing. Place the main housing cap carefully onto the rotation shaft and close the housing.

Note:

The main housing cap must not be cant. Be aware of the rotation shaft and do not apply radial force to the shaft. The rotation shaft and seal could be damaged.



6 MAINTENANCE AND SERVICE

Secure with 3 screws and nuts against release of main housing cap (torque 30 Nm). Mount the encoder protection cap temporary to prevent any damaging or bending of the rotation shaft. Check axial shaft clearance and ease of rotation.

Note:

Take care that you are not bending or damaging the rotation shaft while fixing the screws of the main housing. Use encoder protection cap.

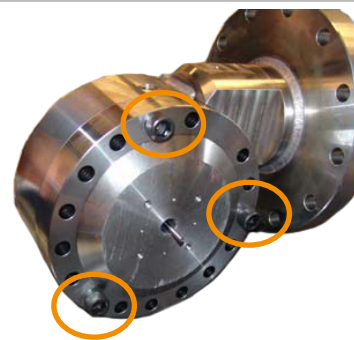

Install the springs one by one onto the rotating shaft. Keep the wire rope lightly tightened (wire rope is fully extracted at this point).

Note:

Only by transducer specific trained persons. The stored energy of the spring may lead to injuries when being mishandled. Avoid guiding the rope over edges or corners.



Turn slowly clockwise. Let the wire rope run into the transducer and turn the spring set at same time (two persons are necessary). If the wire rope is fully drawn into the transducer, apply 3 pre-load turns to the spring set. Fix the spring set with screws (use screw locking device and apply lacquer). Check measurement range and rope forces.

Note:

Don't let the rope snap back. If the rope is retracted freely, this may lead to injuries and the transducer may be damaged.

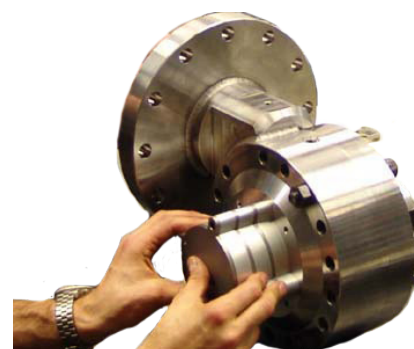

Install and fix the main housing screws (16 pcs.) crosswise. Tighten the screws in 3 steps. First up to 100 Nm, second to 200 and at last to 300 Nm. Screws and nuts greased with MoS2.

Note:

Last step to 300 Nm only with torque spanner. Impact wrench only for first and second step.

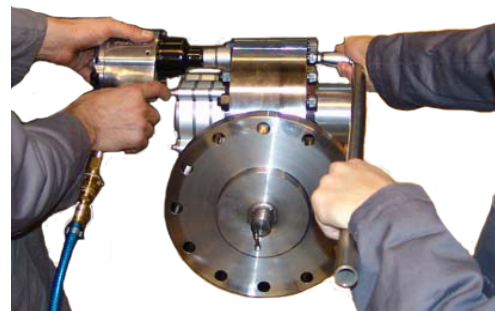

6 MAINTENANCE AND SERVICE

6.5 Changing o-ring seals of flange assembly

Remove 6 screws M12x60, the o-ring and back-up ring of the flange.

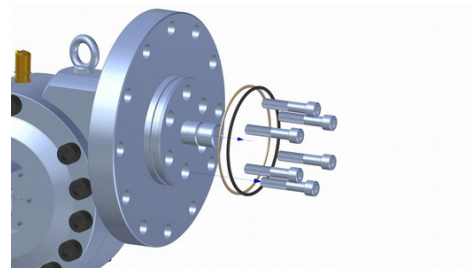

Demount the flange, the shim ring and the 6 o-rings.

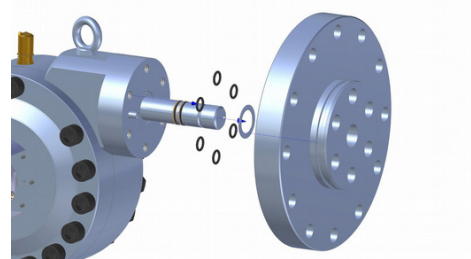

Pull out the filling pipe carefully and remove the feather key

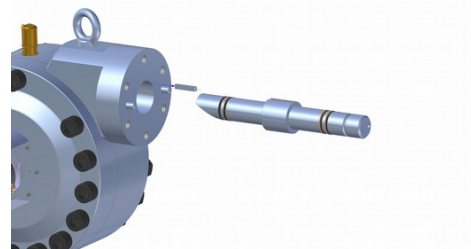

Remove the o-rings and back-up rings. Clean all sealing surfaces. Before replacing the o-rings and back-up-rings grease the filling pipe and mount the new rings.

Note: Take care that you do not mix the assembly sequence! Please refer to the pictures (o-rings are black coloured, back-up rings are brown coloured)!

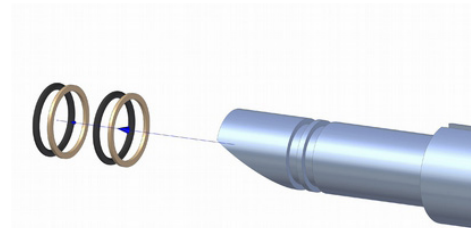

Assembly: Installation in reverse order.

Note:

- ▶ Take care not to damage any o-rings and back-up rings. Always grease the rings and sealing surfaces.
- ▶ While pushing in the filling pipe into the housing gently turn the pipe.
- ▶ Align the slots of the filling pipe and the housing and mount the feather key.
- ▶ Tightening torque of the screws M12x60 is 160 Nm.

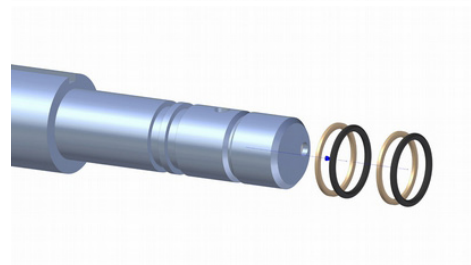

6 MAINTENANCE AND SERVICE

6.6 Final work after dismantling

If the transducer was dismantled and repaired in any way, it has to be checked and tested before reinstalling it to the hydraulic cylinder.

- ▶ Check all screws and mounted parts of the transducer
- ▶ Check encoder output signal (please refer to the encoder guidelines)
- ▶ Check wire rope for any damage
- ▶ Check the rope tension (measure force). Start of range: 10..11.5 N (13..16.5 N). End of range: 29..31.5 N (37..43 N)
- ▶ Carry out pressure test up to 375 bar.
- ▶ Clean the transducer and mount the wire rope protection cap.
- ▶ We recommend to keep your service documents updated with all information about faulty and repaired parts, exchanged parts, date and name of operator etc.



Note: If the sensor is installed in a wet or humid environment it is very important to install the encoder protection cap in such a way, that the gap in the cap shows downwards. Otherwise e.g. rainwater will fill the protection cap and flood the encoder.

6.6.1 Storage

When storing the transducer less than 1 month the oil film built up in the course of the functional test at WayCon will be sufficient protection. The storage room must be dry and free from vapours or etching agents.

If the transducer shall be stored for a longer period (e.g. up to 6 months), all uncoated parts must be provided with an external preservation of e.g. TECTYL or DENSO taping.

6.6.2 Tightening torques for screws

Dimension	Quality	Torque [Nm]	Position
M3	V2A	2	Encoder fixation
M8	V2A	18	Spring housing, encoder cap
M12	12.9	160	flange fixation
M16	12.9	303	Main housing transducer

7 SPARE PARTS

We keep a certain number of spare parts and repair kits at your disposal. With regard to a quick delivery, please specify the type and serial number of the transducer, as well as the required parts according to the list of spare parts. However, since we are not able to have all components on stock all the time, we recommend to keep your own stock of repair kits to avoid expensive standstills.

7.1 Exploded view

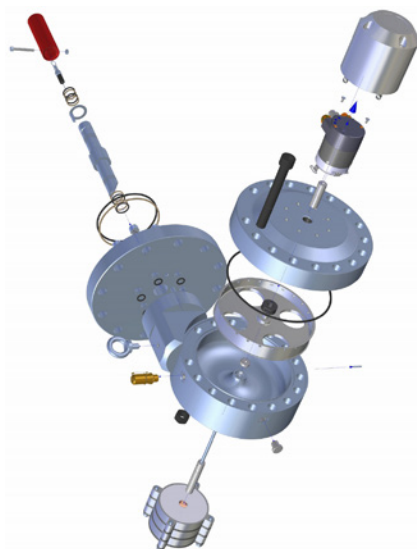

7 SPARE PARTS

7.2 Exploded view - encoder assembly and attachment parts

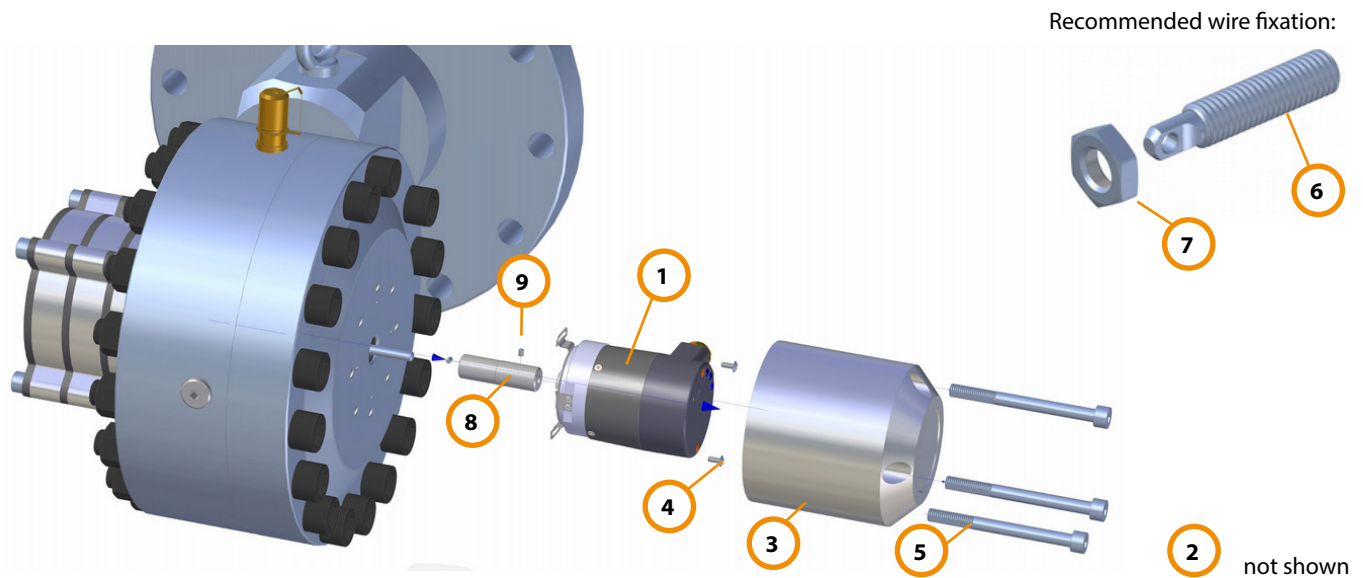

7.2.1 Part list - encoder assembly and attachment parts

SX300-15-...-F2 (encoder and attachment parts)

no.	description	qty	no.	description	qty
1	encoder	1	6	wire fixation unit M8 A2	1
2	mating connector / cable	1	7	counternut DIN 934 M8 A2	1
3	encoder protection cap (includes no. 5)	1	8	encoder adaptor	1
4	encoder screw M3x8	2	9	encoder adaptor screws DIN913 M3x4 A2	2
5	encoder cap screw	3-4			

7.3 Exploded view – flange assembly

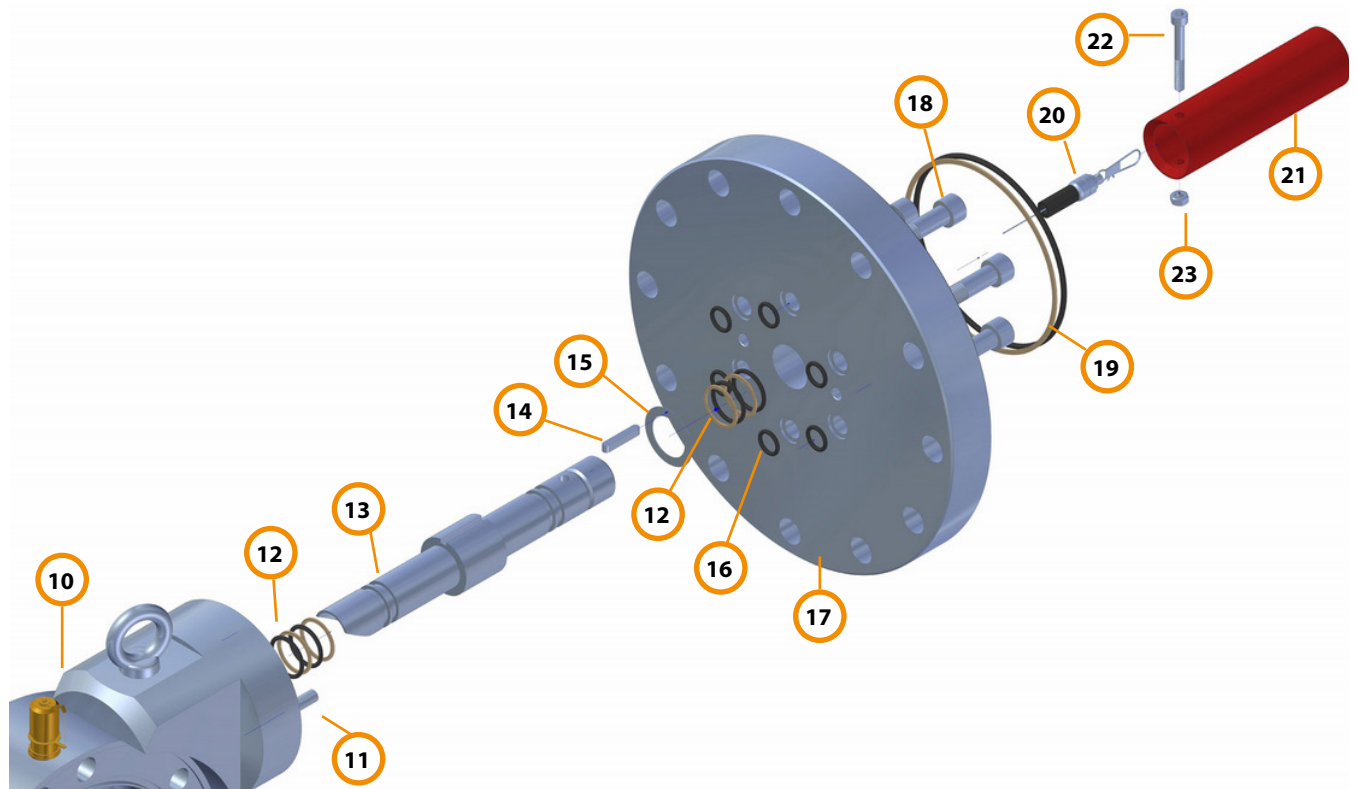

7 SPARE PARTS

7.3.1 Part list – flange assembly

SX300-15-...-F2 (parts for flange assembly)

no.	description	qty	no.	description	qty
10	main housing	1	17	flange F2	2
11	cylinder bolt DIN7 8x20	2	18	screw DIN912 M12x60 12.9	6
12	sealing set filling pipe (4 o-rings/ 4 back-up rings)	1	19	flange sealing set (o-ring/ back-up ring) (SX300-OR1)	1
13	filling pipe	1	20	wire set 10 m (SX300-WS-10) or 15 m (SX300-WS-15)	1
14	feather key DIN6885 5x30	1	21	wire protection cap	1
15	shim ring 28x40x0,2	1	22	screw DIN912 M6x50	1
16	screw sealing set (6 pcs.)	1	23	nut DIN934 M6	1

7.4 Exploded view – transducer housing

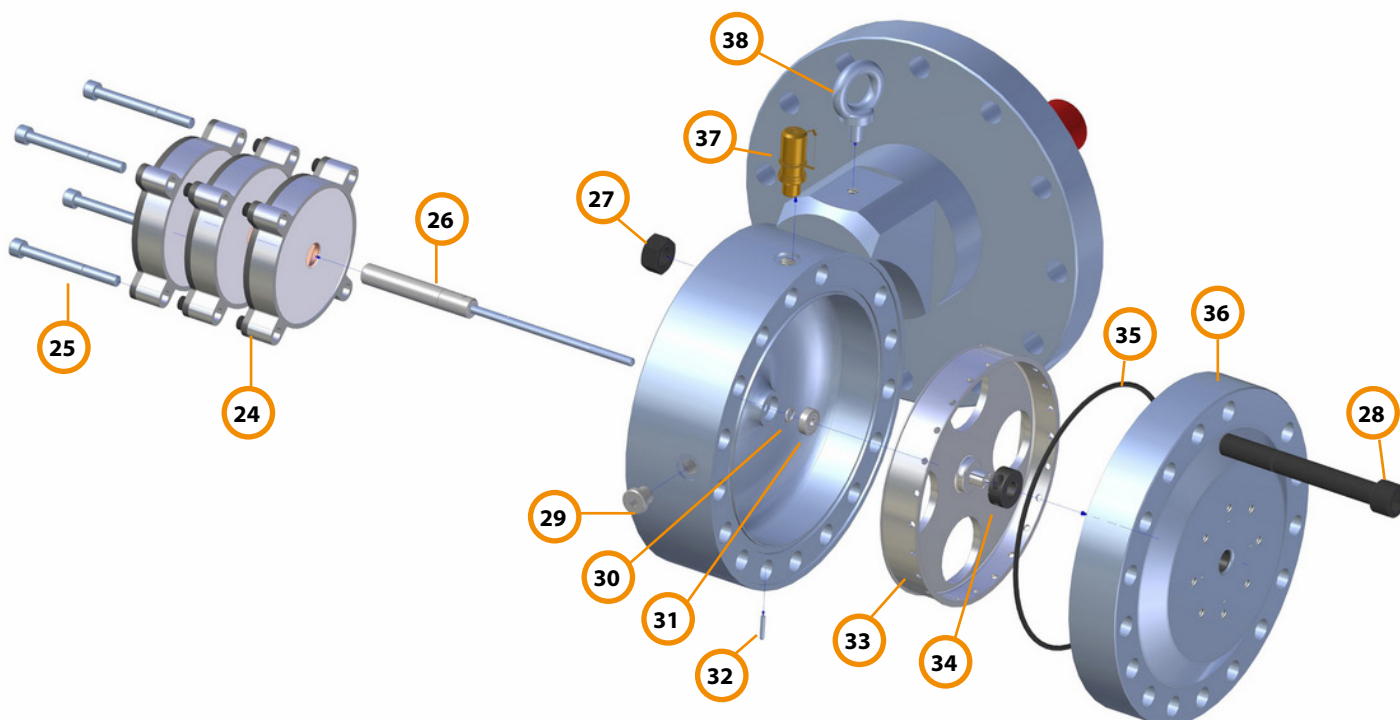

7.4.1 Part list – transducer housing

SX300-15-...-F2 (transducer housing)

no.	description	qty	no.	description	qty
24	spring housing assembly (includes 3 springs and no. 25) (SX300-FED)	1	32	cylinder bolt DIN6325 3x18	1
25	main housing cap	1	33	wire capstan	1
26	rotation shaft	1	34	clamp ring	1
27	housing nut DIN934 M16 (12)	16	35	o-ring 190,1x3,53 (SX300-OR2)	1
28	housing screw DIN912 M16x130 (12.9)	16	36	main housing cap	1
29	screwed sealing plug	1	37	Minimess 1620 (SX300-MIN)	1
30	pressure seal set TRE	2	38	eye bolt DIN580 M10 A2	1
31	ball bearing 626ZZ	2			

8 EXAMPLE TEST REPORT

TEST REPORT



Description pressure test: Filling the sensor with hydraulic oil (HLP 46), applying pressure through the wire outlet to specified testing pressure, check for any damage, leakage or pressure drop about several minutes (>5 min).

Description mechanical test: Checking smoothness of motion, checking measurement range by extracting the wire until mechanical end stop.

Test equipment: Hydraulic cylinder (600 bar max.), test adapter, manometer, oil filling unit measuring tape

Manufacturer: Waycon Positionsmesstechnik GmbH
Mehlbeerenstr. 4, 82024 Taufkirchen
Germany

Marking/Article No: SX300-10-M420AT-F2

Serial No: 17556725

Year of manufacture: 2017

Operating pressure: 300 bar (30 MPa)

Testing pressure: 400 bar (40 MPa)

Nominal measurement range: 10 m

Testing range: 10,30 m

Material insp. certificate: 3.1 B as per EN10204 (DIN 50049)

Test performed: 05th-december-2017

Results: The above mentioned units have passed the pressure and mechanical test successfully.

Taufkirchen/Germany, 05th-december-2017

Markus Storm
Holger Jerzembek

Date

Inspection engineer/technician